

Oleksij Fomin - Juraj Gerlici - Mykola Gorbunov - Alyona Lovska
 Kateryna Kravchenko - Oleksii Burlutski - Tomas Lack*

STUDY INTO IMPROVEMENT OF THE HATCH COVERS OF GENERAL-PURPOSE OPEN WAGONS TO PROVIDE STRENGTH UNDER OPERATIONAL LOADING DIAGRAMS

The article presents the results of research into the strength of the hatch covers of general-purpose open wagons. It was detected that strength of the standard hatch covers is not provided in operational loading diagrams. Therefore, new designs of the hatch covers for open wagons were proposed. The results of the strength calculation, implemented with the finite element method, make it possible to conclude that at basic and additional operational loading diagrams the strength values for proposed designs of hatch covers do not exceed the admissible values. The research conducted can contribute to a higher strength of the carrying structures of the bodies of general-purpose open wagons in operation, thus, guaranteeing a higher operational efficiency of the rail transport.

Keywords: hatch cover, locking support, framing, strength calculation

1. Introduction

The development of foreign economic relations between Eurasian countries mostly depends on the transport industry, the leading component of which is railways. In order to provide the fail-safe transportation it is necessary to supply railways with adequate rolling stock [1-2].

One of the most damaged elements in the carrying structure of open wagon bodies, as the most popular types of wagons in operation, is the hatch cover (Figure 1). It is caused by its considerable operational loading, because this structural element forms the floor of an open wagon.

A frequent cause of damages of the hatch covers in operation is the loading/unloading of open wagon bodies at sea ports and private enterprises.

In order to provide strength of the hatch covers of open wagons, it is necessary to determine and analyze the strength values in operational loading modes.

2. Analysis of recent studies

The study into the stress-strain state of the hatch cover of open wagons, when part of freight falls on it, is presented in [3]. The results of calculation made it possible to conclude that the standard hatch cover design does not satisfy the strength conditions. The strength research into the hatch cover of open wagons under other loading diagrams is not conducted in the study.

Study [4] deals with results of research into the character and influence of different freight bogies on strength of the carrying structures of wagons.

The methods to improve the carrying capacity of open wagon bodies, to provide their fastening strength on the deck of a train ferry, are given in [5].

However, in that study is not covered the problem of the strength research for the hatch covers of open wagons in operational conditions.

Influence of round tubes, introduced in the carrying systems of freight wagons, on the physical-mechanical properties, is studied in [6-7]. The research into dynamic loading and strength of the open wagon body does not consider the hatch covers in the structure. Thus, the model takes into account the elements rigidly interacting.

A longer service life for obsolete open wagons is substantiated in [8]. In order to determine the dynamic loading on the body of an open wagon at shunting impacts the mathematical model was designed, the solution of which was considered for the research into strength of the body of an open wagon with consideration of operational wear of structural elements.

Besides that, the works do not study the strength of the hatch covers in open wagons for operational loading modes.

The observation of structural peculiarities of open wagons is provided in [9]. It considers advantages and disadvantages of the failure-proof designs of open wagons and tendencies of their improvement.

However, methods to improve hatch covers for open wagons are not considered.

Problems of the rolling stock design for heavy-cargo transportation are studied in [10-11]. Dynamics and strength

* ¹Oleksij Fomin, ²Juraj Gerlici, ³Mykola Gorbunov, ⁴Alyona Lovska, ⁵Kateryna Kravchenko, ⁶Oleksii Burlutski, ⁷Tomas Lack

¹Department of Cars and Carriage Facilities, State University of Infrastructure and Technology, Ukraine

²Department of Transport and Handling Machines, University of Zilina, Slovakia

³Department of Rail Transport, Institute of Transport and Logistics, Volodymyr Dahl East Ukrainian National University, Ukraine

⁴Department of Cars, Ukrainian State University of Railway Transport, Ukraine

⁵Department of Mechanics and Machine Design, Ukrainian State University of Railway Transport, Ukraine

E-mail: fominaleksejvictorovic@gmail.com



Figure 1 The basic damages in the hatch covers of open wagons in operation: a - break in the framing, b - tear of the locking support, c - damages in the framing, d - tear of the sheet

are studied with advanced methods using ProMechanica and CosmosWorks software. While designing the carrying structure of a carrier, the possibility to use various materials for it is investigated, as well.

The influence of friction between the body and the bogie on dynamic values of a wagon motion is presented in [12]. The modelling was conducted with mathematical techniques in DYNRAIL software.

However, the studies mentioned do not pay attention to determination of the strength values for the hatch covers of general-purpose open wagons.

Research into the dynamics of a wagon with multi-body methods is presented in [13]. The computation was made in the MSC Adams software complex. Study [14] determines the influence of structural peculiarities of wheel sets on the motion of transport facilities on curve sections.

All investigations mentioned above do not study the strength of the structural elements of transport facilities under operational loading.

3. Objective of the article

The study presents possibilities to improve hatch covers for general-purpose open wagons to provide adequate strength at operational loading diagrams. To achieve the objective the following tasks are presented:

1. Strength calculation of the hatch covers of a general-purpose open wagon. Substantiation of its required improvement;

2. Improvements of the hatch covers of a general-purpose open wagon to provide adequate strength at operational loading diagrams;
3. Strength calculation of the improved hatch covers for general-purpose open wagons;
4. Durability calculation of the improved hatch covers for general-purpose open wagons.

4. Presentation of the basic material of the article

In order to determine the strength values of the hatch covers for the general-purpose open wagons, the spatial model of a hatch cover was built in the SolidWorks software and strength was calculated with the finite element method in the CosmosWorks software.

The strength calculation was made at basic loading diagrams for hatch covers in compliance with normative documents [15-17]:

- effect of the equally distributed loading $P_o = 69.9$ kN of the hatch cover area which consists of the gravity force of the hatch cover and dynamic loading;
- effect from a load of $P'_o = 50$ kN distributed in the center (25x25 cm) of the hatch cover;
- effect from cyclic impact loads on the hatch cover, the numerical values of which equal 500; and
- fall of 150-kg freight on the hatch cover from a height of 3 m.

The calculations conducted demonstrated that when 150-kg freight fell on the hatch cover from a height of 3 m, the maximum

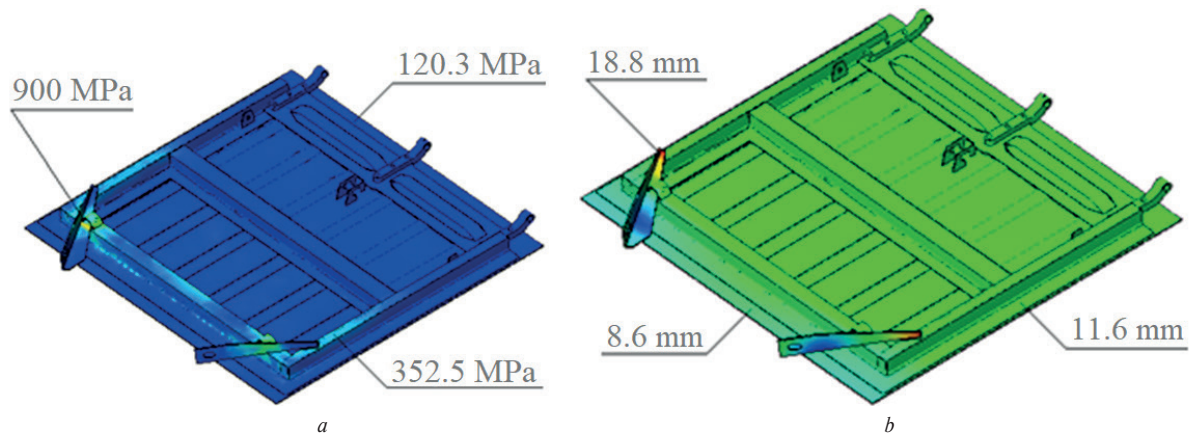

Figure 2 Results of the strength calculation for the hatch cover of an open wagon when 150-kg freight falls on the hatch cover from a height of 3 m, a - stress state, b - displacements in the units

equivalent stresses appeared in the locking supports and equaled approximately 900 MPa (Figure 2a), the maximum displacements in the structural units were fixed at the locking supports and equaled 18.8 mm (Figure 2b), the maximum strains were $1.72 \cdot 10^{-2}$. Thus, at a given loading diagram the strength of the hatch cover was not provided [15-17].

At other basic loading diagrams, the strength values of the hatch cover were within the admissible ones.

For improved strength research of the hatch cover of an open wagon the additional diagrams of possible loads in operation were considered:

- 1) simulation of the hatch cover opening while unloading the freight - non-torsion (without consideration of operation of torsion(s)) and non-simultaneous (at first for one of the supports) impact of the hatch cover against the supports of the intermediate beams of the wagon frame with the maximum opening angle;
- 2) simulation of the hatch cover opening while unloading freight - non-torsion (without consideration of operation of torsion(s)) and simultaneous impact of the hatch cover against supports of the intermediate beams of the wagon frame with the maximum opening angle;
- 3) non-simultaneous opening of the hooks - the hatch cover of the loaded wagon rests on one hook and one support (with one hook open and one closed); and
- 4) tightening (closing) of the hatch cover of an unloaded wagon with force.

The calculations conducted showed that at a non-torsion non-simultaneous impact against the supports of the intermediate beams of the wagon frames the maximum equivalent stresses on the hatch cover appeared at the hinge and equaled approximately 400 MPa; the maximum displacements in the structural units were fixed in the corners of the hatch cover from the locking supports and were approximately 11.7 mm; the maximum strains were $2.6 \cdot 10^{-3}$.

For non-simultaneous opening of the hooks of the hatch cover the maximum equivalent stresses appeared in the hinges, diametrically placed to the locking supports, the mechanism of which was closed; they equaled approximately 400 MPa. The maximum displacements in structural units were detected in the area of the locking supports, whose mechanism was closed;

they equaled approximately 11.5 mm, the maximum strains were $7.6 \cdot 10^{-3}$.

At other additional loading diagrams the strength values for the hatch cover were within the admissible ones.

In order to provide strength of the hatch cover the authors proposed essentially new structures (Figure 3).

The design description of a polymaterial framing of variant I for the hatch cover with standard fastenings (Figure 3a):

- plane of the hatch cover consisted of the upper and lower sheets with the gap of elastic (viscous-elastic) substance;
- the upper 2.5-mm corrugated sheet;
- the lower 2.5-mm corrugated sheet. The corrugations reflected the upper sheet on the admissible sections;
- framing was made with an E-shaped profile of a 5-mm curved sheet filled with elastic (viscous-elastic) substance along the perimeter and in the middle of the hatch cover. Its height was adopted for installation of standard fastening elements on the cross beam and lower framing of an open wagon;
- hinges of the hatch covers (elements interacting with the center sill) were welded on the hatch cover (not riveted); and
- fastening supports to the lower framing of the side walls of a standard structure.

A feature of the hatch cover in variant II was the structure of the two horizontal sheets with a substance of elastic-viscous damping characteristics in between. The framing of the hatch cover was of E-shaped profile (Figure 3b) curved of a sheet and filled with an elastic (viscous-elastic) substance along the perimeter and in the middle part of the hatch cover. Its height was adopted for mounting standard fastening elements to the center sill and the lower framing of an open wagon. The hinges of the hatch cover (elements that interact with the center sill) were welded on the hatch cover (not riveted) and the supports were mounted to the lower framing of the side walls of a standard structure.

Variant III of the hatch cover was characterized by the coating made of a plain sheet (Figures 3c, 3d) of a convex configuration (pre-loaded), to provide the adequate strength at impact loading. Besides, the hatch cover framing was filled with a viscous substance of damping characteristics.

The variants of the hatch cover for open wagons proposed were designed for strength at the basic and additional loading

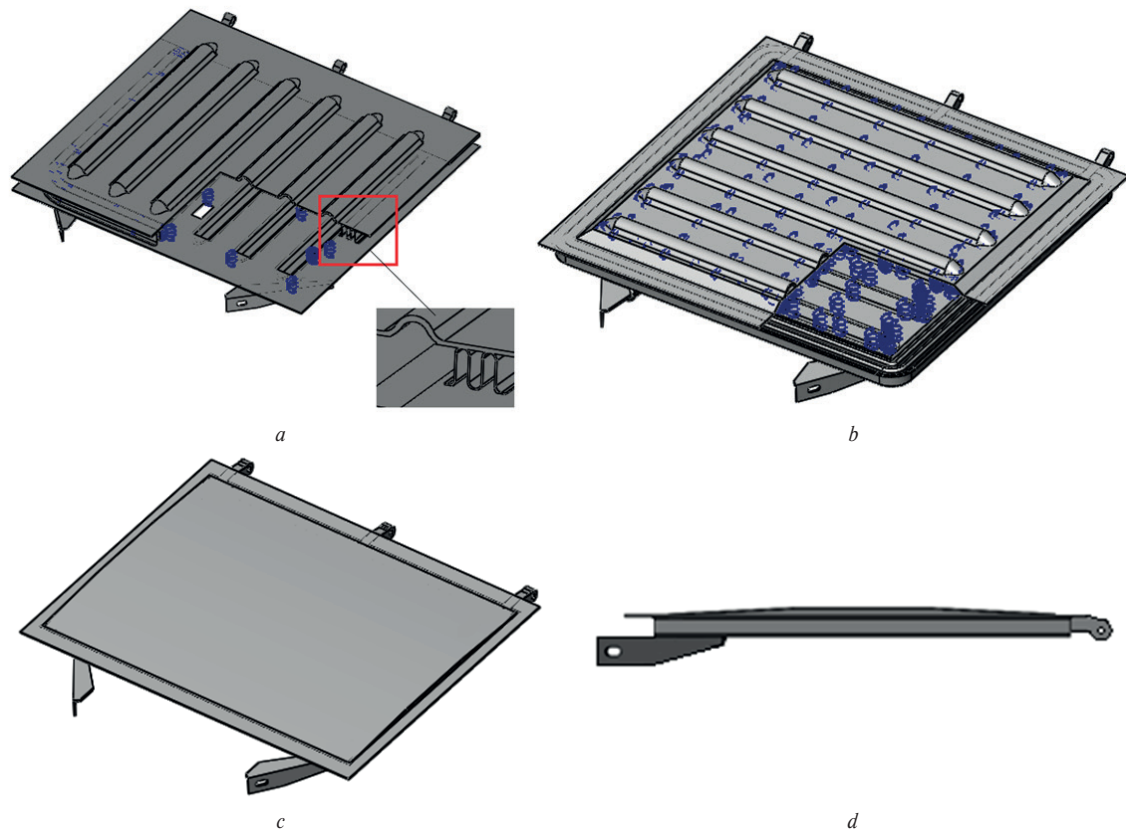

Figure 3 The improved structures of the hatch covers, a - variant I, b - variant II, c and d - variant III

diagrams mentioned above. The results of the calculation are given in Table 1. The maximum loading of the hatch covers proposed could be observed when 15-kg freight fell on it from a height of 3 m and the strength of the hatch covers was provided [15-17]. Results of the strength calculations of the improved hatch covers at the least favorable diagram are given below.

The improved structures of the hatch covers were also calculated for reliability at the least favorable loading modes.

At a symmetric loading cycle the reliability of the hatch covers (in loading cycles) was determined by the safety factor of fatigue strength [18]:

$$N = N_0 \cdot n^m, \quad (1)$$

where

N_0 is the test base;

n is the safety factor of fatigue strength;

m is the parameter of a fatigue curve.

$$n = \frac{\sigma_{-1}}{\sigma_a}, \quad (2)$$

where

σ_{-1} is the endurance limit, MPa;

σ_a is the amplitude stress, MPa.

$$m = \frac{\ln N_0 - \ln N}{\ln \sigma_a - \ln \sigma_{-1}}, \quad (3)$$

where N is the number of cycles before damage.

For steel the endurance limit values can be determined as:

$$\sigma_{-1} \approx (0,1 - 0,5) \cdot \sigma_{BP}, \quad (4)$$

where σ_{BP} is the strength limit, MPa;

Considering a non-symmetric loading cycle the hatch cover reliability was determined as:

$$N = N_0 \cdot \left(\frac{\sigma_{-1}}{\sigma_a + \psi_1 \cdot \sigma_m} \right)^m, \quad (5)$$

where σ_m is the average stress value, MPa;

ψ_1 is the variable, the numeric value of which can be determined as $\psi_1 = \frac{2 \cdot \sigma_{-1} - \sigma_0}{\sigma_0}$;

σ_0 is the endurance limit at the zero additional loading mode, MPa.

The calculations conducted for all the variants of improved hatch covers demonstrated that the adequate strength was provided.

5. Conclusions

From results of the research conducted the following conclusions can be made:

1. In order to provide the adequate operational strength of the hatch covers of a general-purpose open wagon the authors proposed some improvements.
2. Results of the strength calculation of improved hatch covers showed that strength values at basic and additional operational loading diagrams are provided.

Table 1 Results of the strength calculations of the improved hatch covers

| Loading diagrams | Maximum equivalent stresses, MPa | | | Displacements in the structural units, mm | | | Deformations | | |
|--|----------------------------------|-----|-------|---|----|------|----------------------|----------------------|----------------------|
| | I | II | III | I | II | III | I | II | III |
| effect from the uniformly distributed load across the hatch cover area | 150 | 170 | 140 | 13 | 7 | 14 | $5.34 \cdot 10^{-1}$ | $1.2 \cdot 10^{-1}$ | $1.61 \cdot 10^{-3}$ |
| effect from the distributed load on the center (25x25) of the hatch cover | 130 | 140 | 130 | 10 | 4 | 10 | $6.87 \cdot 10^{-3}$ | $7.91 \cdot 10^{-3}$ | $1.14 \cdot 10^{-3}$ |
| drop of 150-kg freight on the hatch cover from a height of 3 m | 220 | 220 | 220 | 13 | 7 | 13 | $5.91 \cdot 10^{-1}$ | $1.18 \cdot 10^{-1}$ | $1.91 \cdot 10^{-3}$ |
| Additional | | | | | | | | | |
| non-torsion non-simultaneous impact of the hatch cover on the supports of the intermediate beams of the frame | 120 | 150 | 183.5 | 4 | 10 | 3.41 | $8.5 \cdot 10^{-2}$ | $3.4 \cdot 10^{-2}$ | $1.24 \cdot 10^{-3}$ |
| non-torsion simultaneous impact of the hatch cover against the supports of the intermediate beams of the frame | 60 | 90 | 85.9 | 3 | 9 | 0.94 | $6.7 \cdot 10^{-2}$ | $2.68 \cdot 10^{-2}$ | $7.06 \cdot 10^{-4}$ |
| non-simultaneous opening of the hooks | 200 | 200 | 214.2 | 14.4 | 9 | 17.9 | $5.2 \cdot 10^{-1}$ | $2.65 \cdot 10^{-2}$ | $2.1 \cdot 10^{-3}$ |
| tightening (closing) of the hatch cover of an unloaded wagon with force | 75 | 100 | 6.3 | 5.1 | 9 | 0.36 | $2.24 \cdot 10^{-2}$ | $2.44 \cdot 10^{-2}$ | $3.75 \cdot 10^{-5}$ |

- The calculation for reliability of the improved hatch covers at symmetrical and non-symmetrical loading cycles was conducted. The results made it possible to conclude that for all the variants of improved hatch covers the reliability is provided.
- Implementation of the proposed hatch covers for open wagons in operation can decrease the amount of damaged freight and encourage higher efficiency of open wagons.

References

- FOMIN, O., et al. Dynamic loading of the tank container on a flat wagon considering fittings displacement relating to the stops. *MATEC Web of Conferences* [online]. 2018, **234**(2), 05002. ISSN 2261-236X. Available from: <https://doi.org/10.1051/mateconf/201823405002>
- GORBUNOV, M., et al. New principle schemes of freight cars bogies. *Manufacturing Technology* [online]. 2018, **18**(2), p. 233-238. ISSN 1213-2489/ISBN 978-80-7414-325-0. Available from: <https://doi.org/10.21062/ujep/83.2018/a/1213-2489/MT/18/2/233>
- PUTIATO, A. V. Modelling of stress-strain state of the hatch cover of an open wagon when part of freight drops on it. Simulation of the stress-strain state of the gondola cover when falling pieces of cargo. *Mechanics. Research and teaching materials*. 2011, **5**, p. 113-122.
- FOHR, J., et al. Metal and composite intermodal containers in comparative cold tests with wood chips. *Journal of Sustainable Bioenergy Systems* [online]. 2015, **5**(01), p. 32-39. ISSN 2165-400X/eISSN 2165-4018. Available from: <https://doi.org/10.4236/jsbs.2015.51003>
- LOVSKA, A. A. Peculiarities of computer modeling of strength of body bearing construction of gondola car during transportation by ferry-bridge. *Metallurgical and Mining Industry* [online]. 2015, **1**, p. 49-54. ISSN 2076-0507/eISSN 2078-8312. Available from: http://www.metaljournal.com.ua/assets/Journal/english-edition/MMI_2015_1/10%20Lovska.pdf
- FOMIN, O. V., et al. The influence of implementation of circular pipes in load-bearing structures of bodies of freight cars on their physico-mechanical properties. *Scientific Bulletin of National Mining University*. 2017, **6**(162), p. 89-96. ISSN 2071-2227/eISSN 2223-2362.
- FOMIN, O.V. Modern requirements to carrying systems of railway general-purpose gondola cars. *Metallurgical and Mining Industry*. 2014, **5**, p. 31-43. ISSN 2076-0507.

- [8] OKOROKOV, A. M., et al. Research into a possibility to prolong the time of operation of universal semi-wagon bodies that have exhausted their standard resource. *Eastern-European journal of enterprise technologies* [online]. 2018, **3(7)**(93), p. 20-26. ISSN 1729-3774/eISSN 1729-4061. Available from: <https://doi.org/10.15587/1729-4061.2018.131309>
- [9] MYAMLIN, S. V., KEBAL, I. U., KOLESNYKOV S. R.: Design review of gondola car. Science and transport progress (in Ukrainian). *Bulletin of the Dnepropetrovsk National University of Railway Transport*. 2014, **6**(54), p. 136-145.
- [10] PRIYA DIVYA, G., SWARNAKUMAR, I. A. Modeling and analysis of twenty tonne heavy duty trolley. *International Journal of Innovative Technology and Research* [online]. 2014, **2**(6), p. 1568-1580. ISSN 2320-5547. Available from: <http://www.ijitr.com/index.php/ojs/article/view/421/pdf>
- [11] DIZO, J., et al. Modification and analyses of structural properties of a goods wagon bogie frame. *Diagnostyka* [online]. 2019, **20**(1), p. 41-48. ISSN 1641-6414/eISSN 2449-5220. Available from: <https://doi.org/10.29354/diag/99853>
- [12] MYAMLIN, S., et al. Research of friction indices influence on the freight car dynamics. *TEKA. Commission of Motorization and Energetics in Agriculture* [online]. 2013, **13**(4), p. 159-166. Available from: <http://eadnurt.diiit.edu.ua/bitstream/123456789/2160/1/159-166.pdf>
- [13] WOJCIK, K., et al. Multi-body simulations of railway wagon dynamics. *Journal of KONES. Powertrain and Transport* [online]. 2012, **19**(3), p. 499-506. ISSN 1231-4005/eISSN 2354-0133. Available from: <https://doi.org/10.5604/12314005.1138164>
- [14] HAUSER, V., et al. Impact of wheelset steering and wheel profile geometry to the vehicle behavior when passing curved track. *Manufacturing Technology*. 2017, **17**(3), p. 306-312. ISSN 1213-2489/ISBN 978-80-7414-325-0.
- [15] GOST UA 7598:2014. Freight wagons. General requirements for the calculation and design of new and upgraded rail wagons 1520 mm (non-self-propelled) (in Ukrainian). 2015.
- [16] GOST 33211-2014. Freight wagons. Requirements for strength and dynamic qualities (in Russian). Moscow, 2016.
- [17] EN 12663-2. Railway applications - structural requirements of railway vehicle bodies. Part 2: Freight wagons.
- [18] USTYCH, P. A., KARPYCH, V. A., OVECHNYKOV, M. N.: *Reliability of rail non-tractive rolling stock* (in Russian). Moscow, Variant, 1999.