

PAPER • OPEN ACCESS

Determination of the regularities of the covered wagon supporting structure dynamic loading when conducting fire from it in the horizontal plane

To cite this article: O Fomin *et al* 2021 *IOP Conf. Ser.: Mater. Sci. Eng.* **1021** 012004

View the [article online](#) for updates and enhancements.

Determination of the regularities of the covered wagon supporting structure dynamic loading when conducting fire from it in the horizontal plane

O Fomin¹, A Lovska^{2,6}, J Gerlici³, Yu Fomina³, D Fedosov-Nikonov⁴,
P Prokopenko¹

¹Department of Cars and Carriage Facilities, State University of Infrastructure and Technologies, Kyrylivska str., 9, Kyiv, Ukraine, 04071

²Department of wagons, Ukrainian State University of Railway Transport, Feuerbach sq., 7, Kharkiv, Ukraine, 61050

³Department «Transport and handling equipment», University of Zilina in Zilina, Univerzitna 8215/1, 010 26 Zilina, Slovakia, 01026

⁴State Enterprise “Ukrainian Research Institute of Wagon Building”, Prikhodko str, 33, Kremenchuk, Ukraine, 39621

⁶alyonalovskaya.vagons@gmail.com

Abstract. A study of the supporting structure dynamic loading of a covered wagon for the military equipment transportation and for firing has been carried out. A mathematical model has been drawn for this purpose, taking into account the vertical and angular displacements relative to the longitudinal axis (side rolling) of the wagon supporting structure when firing. Accelerations as the components of the dynamic load acting on the wagon supporting structure have been determined. It was found that the accelerations acting on the wagon supporting structure in the vertical plane were about 6.0 m/s^2 (0.6 g). In the horizontal plane, the accelerations were 2.6 m/s^2 (0.26 g). That is, the wagon movement can be assessed as “satisfactory”. To reduce the wagon dynamic loading during the conduct of fire, it is proposed to install elastic vibration dampers under the support sectors. In this case, the horizontal acceleration was about 2 m/s^2 (0.2 g). Taking into account the proposed technical solutions, the wagon dynamic load is reduced by about 25% in comparison with the case of the rigid interaction of the sector with the frame. The strength analysis of the covered wagon bearing structure has been carried out. It was found that the maximum equivalent stresses are concentrated in the area of the front stops and are about 315 MPa. The conducted research will contribute to the creation of recommendations for the design of covered wagons for the military equipment transport and for firing, as well as to increase the efficiency of the railway transport operation..

1. Introduction

The railway industry development at the present stage of the transport system functioning requires the commissioning of rolling stock innovative structures, in particular, wagons. In this case, special attention should be paid to their supporting structures. It is not only about improving technical and economic indicators and introducing new progressive materials, but also about creating multifunctional structures.

Multifunctionality of the supporting structure means the ability to perform more than one function. Therefore, it is proposed to put into operation wagons that would provide the possibility not only of



transporting goods, but also of using, for example, for the country military-strategic purposes. That is a very urgent and important task today.

It is known that flat wagons are most widely used for the military equipment transportation. However, for the transportation of military equipment that needs atmospheric precipitation protection, the use of these wagon types is not advisable. Therefore, it is proposed the commissioning of covered wagons for the military equipment transportation, as well as the possibility of conducting fire effects while moving. It is important to note that the issue of designing such wagons has not yet received due attention. In addition, the regulatory framework in accordance with which the modern wagon structures are designed does not take into account the loads that can act on them during the conduct of fire. This makes necessary research in this direction and the creation of appropriate recommendations.

Features of bench tests for fatigue resistance of covered wagons dummy units are described in [1]. The static and dynamic loads of the prototypes were carried out on the hydroimpulse test bench for testing large-sized structures. The study of the reliability of the obtained results are presented.

The results of a numerical and experimental study of the wagon supporting structure strength are given in papers [2, 3]. A covered wagon of type 11-9962 was chosen as a prototype. The method of electrical strain gauging was used as an experimental research method. The carried out studies confirmed the feasibility of the technical solutions adopted while designing.

It is important to note that when designing and calculating wagons, the standard load values were taken into account. That is, the overtime load regimes of the wagon bearing structure, including during the military equipment transportation and the conduct of fire, were not taken into account.

Prospects for the use of extra-fine steels in rail car building are illustrated in [4]. The analysis of the characteristics of steels with a high strength class, which are manufactured in Russia and abroad, is carried out. An assessment of the reduction in the structure weight when using high-strength steels is given. However, the authors did not consider the prospects for the introduction of these steels in specialized wagon designs, including for the transportation of military equipment and fire exposure.

The features of the strength analysis of a modern covered wagon structure are highlighted in [5]. In this case, the means of computer simulation of strength by the finite element method were used. However, the loads that may act on a wagon during the transportation of military equipment are not taken into account when calculating the wagon load-bearing structure. It is also not specified in the paper, if it is possible to conduct the fire from this wagon type while moving.

Research on optimization of the wagon supporting structure is carried out in a paper [6]. To reduce the material consumption of the wagon, it is proposed to manufacture its supporting structure from aluminium panels. The component of these panels is a material with elastic characteristics, which helps to reduce the dynamic loading of the supporting structure in operation. At the same time, the authors limited themselves to taking into account the standard values of the loads acting on the wagon in operation.

The determination of the dynamic loading of the wagon supporting structures is carried out in [7, 8]. Mathematical models that allow to obtain accelerations as components of the dynamic load acting on the wagon supporting structures are presented. The obtained results have been confirmed by computer simulation using the finite element method. However, the case of wagon overtime loading when transporting military equipment and conducting fire was not taken into account.

The purpose of the article is to determine the regularities of the dynamic loading and strength of the supporting structure of a covered wagon for military equipment transportation and for conducting fire in a horizontal plane while moving. To achieve this, the following tasks have been identified:

- to create a computer model of the supporting structure of a covered wagon for military equipment transportation and for conducting fire;
- to carry out the dynamic loading mathematical simulation of the supporting structure of a covered wagon for military equipment transportation and for conducting fire;
- to determine the main strength indicators of the supporting structure of a covered wagon for military equipment transportation and for conducting fire, and to determine the natural oscillation frequencies of the covered wagon supporting structure.

2. Computer model creation of the supporting structure of a covered wagon for military equipment transportation and for conducting fire

It is proposed to create a specialized covered wagon (Figure 1) to transport military equipment and to conduct fire while moving. A covered wagon of the type 11-217 was used as a prototype. Graphic work on the model designing was carried out in the SolidWorks software. The peculiarity of the wagon is that its supporting structure has a sliding roof. This makes possible to conduct fire in the vertical plane.

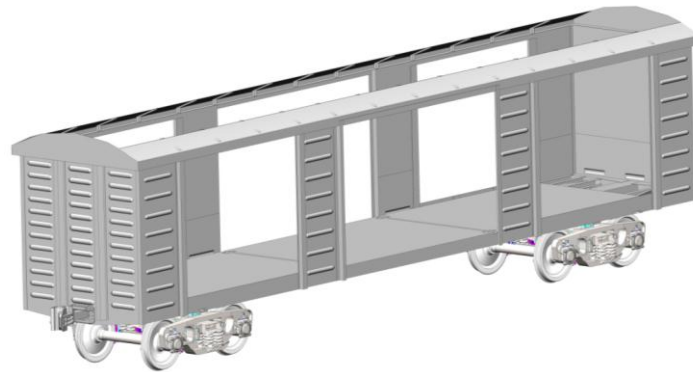

Figure 1. Covered wagon for military equipment transportation and for conducting fire.

Also, the wagon is equipped with a movable double-folding door for loading military equipment, as well as for conducting fire in a horizontal plane. In this case, military equipment is located on special support areas on the wagon frame. It provides for possible to equip the support areas with wheel stops, as well as with other devices for fastening military equipment. The wagon frame is identical in design to the prototype wagon frame. The wagon load-bearing structure is supported by typical bogies model 18-100. The possibility of using bogies of more promising designs under the wagon body is envisaged.

2. Dynamic loading mathematical simulation of the supporting structure of a covered wagon for transporting military equipment and for conducting fire

In order to determine the wagon dynamic loading during the conduct of fire, mathematical simulation has been carried out. The studies were carried out in a plane coordinate system. The design scheme is shown in Figure 2. It has been taken into account that shots are fired from three military installations simultaneously. The muzzle energy of one piece of military equipment is about 90 kJ. When formulating differential equations of motion, it was assumed that the wagon supporting structure leans on two typical bogies model 18-100 having the corresponding technical characteristics.

In this case, the differential equations of motion describing the oscillations of the wagon supporting structure during fire shots in the horizontal plane have the form:

$$\begin{cases} M_{CW} \cdot \ddot{q}_1 + c \cdot q_1 = P_{FR} \left(\text{sign}(\dot{\Delta}_1 - \dot{\Delta}_2) + \text{sign}(\dot{\Delta}_1 + \dot{\Delta}_2) \right) + P_f, \\ I_{CW} \cdot \ddot{q}_2 + c \cdot b \cdot q_2 = P_{FR} \cdot b \left(\text{sign}(\dot{\Delta}_1 - \dot{\Delta}_2) + \text{sign}(\dot{\Delta}_1 + \dot{\Delta}_2) \right) + M_f, \end{cases} \quad (1)$$

$$\Delta_1 = q_1 - b \cdot q_2, \quad \Delta_2 = q_1 + b \cdot q_2, \quad (2)$$

where M_{CW} is the wagon supporting structure weight; I_{CW} is the inertia moment of the wagon supporting structure relative to the longitudinal axis; c is the stiffness of the spring set coils; P_{FR} is the dry friction force in the spring set; b is the half-width of the wagon supporting structure; P_f is the force that is transmitted to the wagon supporting structure when conducting fire; M_f is the force moment acting on the wagon supporting structure when conducting fire.

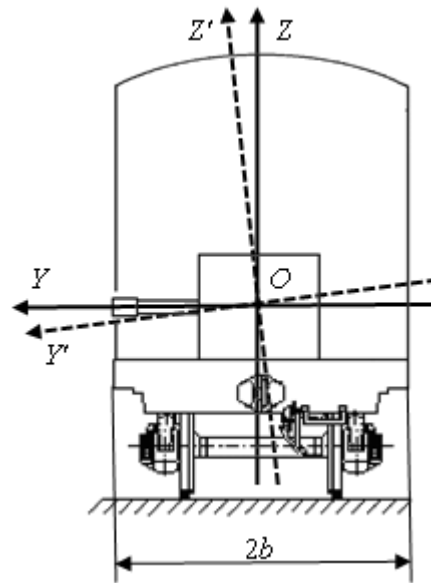

Figure 2. Design scheme of a covered wagon.

The calculation has been carried out by the Runge-Kutta method in the MathCad software [9 – 11]. The calculation results are shown in Figures 3, 4. It is found that the accelerations acting on the wagon supporting structure in the vertical plane are about 6.0 m/s^2 (0.6 g). The accelerations are 2.6 m/s^2 (0.26 g) in the horizontal plane. That is, the wagon motion can be assessed as "satisfactory".

In order to reduce the wagon dynamic loading during the conduct of fire in motion, the case of installing elastic vibration absorbers under the support areas is also considered. In this case, the mathematical model mentioned above is reduced to the form:

$$\begin{cases} M_{cw} \cdot \ddot{q}_1 + c \cdot q_1 = P_{FR} \left(\text{sign}(\dot{\Delta}_1 - \dot{\Delta}_2) + \text{sign}(\dot{\Delta}_1 + \dot{\Delta}_2) \right) + P_f, \\ I_{cw} \cdot \ddot{q}_2 + c \cdot b \cdot q_2 = P_{FR} \cdot b \left(\text{sign}(\dot{\Delta}_1 - \dot{\Delta}_2) + \text{sign}(\dot{\Delta}_1 + \dot{\Delta}_2) \right) + M_f - M_a, \end{cases} \quad (3)$$

where M_a is the moment acting on the support area when conducting fire.

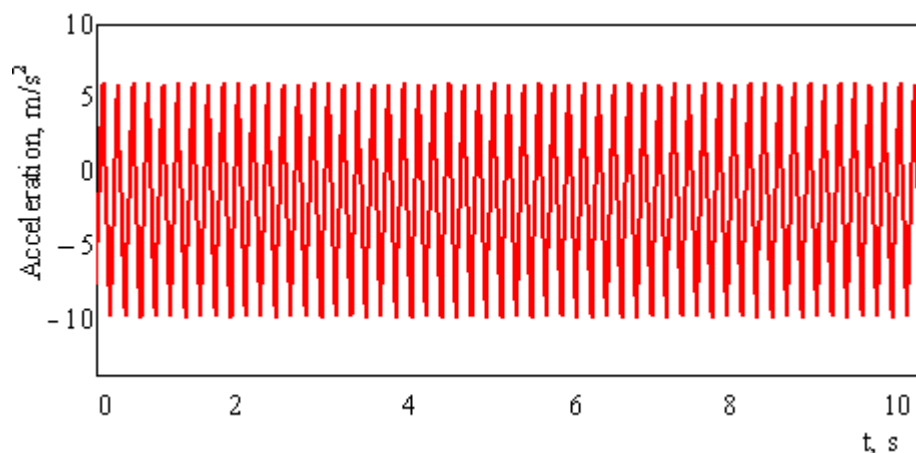

Figure 3. Accelerations acting on the covered wagon supporting structure in the vertical plane.

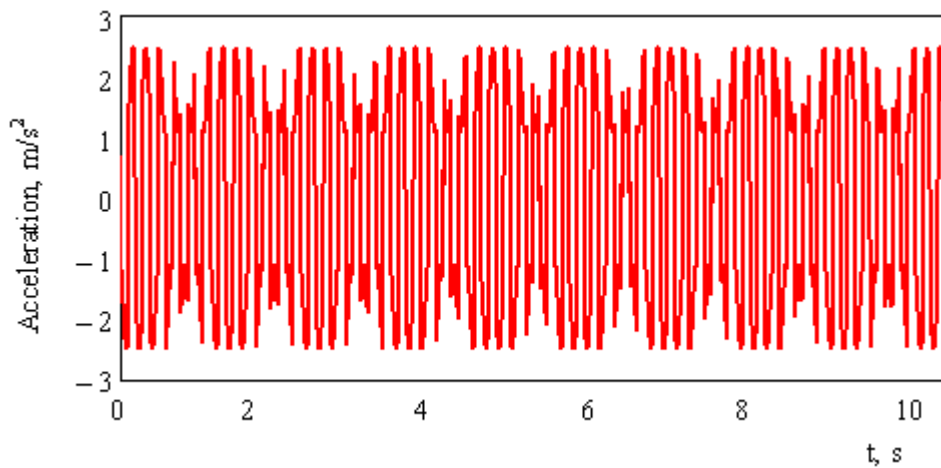

Figure 4. Accelerations acting on the covered wagon supporting structure in the horizontal plane.

The computational scheme of the support area is shown in Figure 5. When carrying out the calculations, it has been taken into account that the impact absorbers work during angular movements of the wagon. That is, when formulating differential equations of motion, the angular stiffness of the impact absorbers has been taken into account.

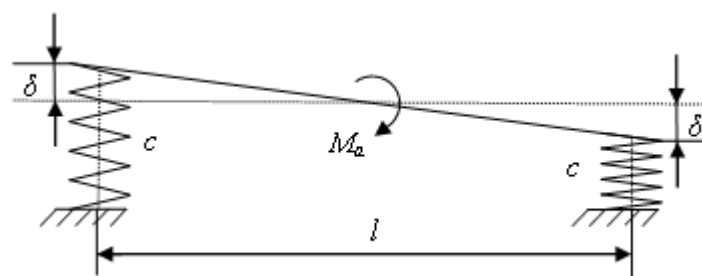

Figure 5. Design scheme of the support area.

The calculation results made it possible to establish that the impact absorbers stiffness should be in the range from 3 kN/m to 10 kN/m. The calculation results for the impact absorber stiffness of 3 kN/m are shown in Figures 6, 7.

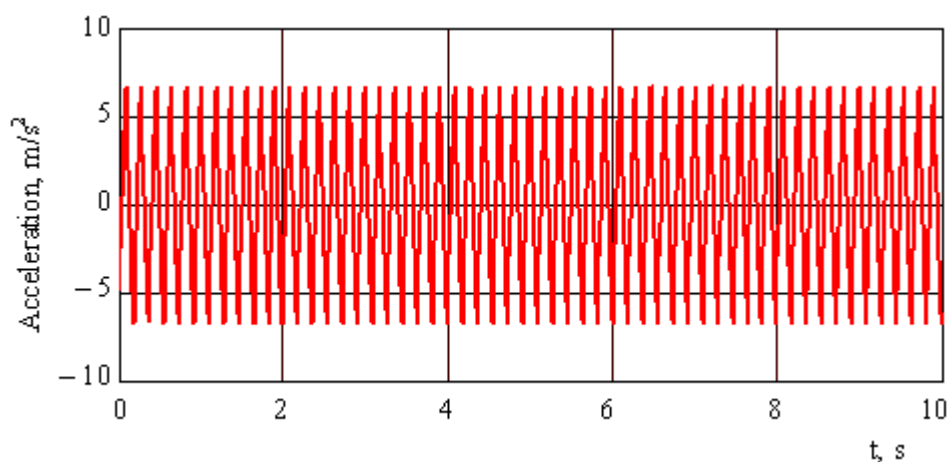

Figure 6. Accelerations acting on the covered wagon supporting structure in the vertical plane.

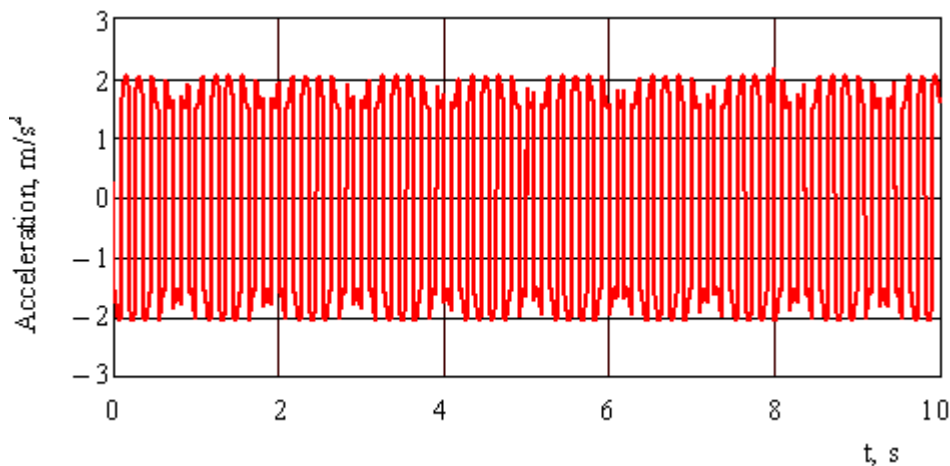

Figure 7. Accelerations acting on the covered wagon supporting structure in the horizontal plane.

In this case, the horizontal accelerations were about 2 m/s^2 (0.2 g). So, with the use of impact absorbers in the supporting sectors, it becomes possible to reduce the wagon dynamic loading in comparison with the case of the rigid interaction of the sector with the frame by almost 25%.

The study of accelerations acting on the wagon supporting structure at different angles of firing from the military equipment was also carried out (Figure 8). The calculation results are shown in Figure 9.

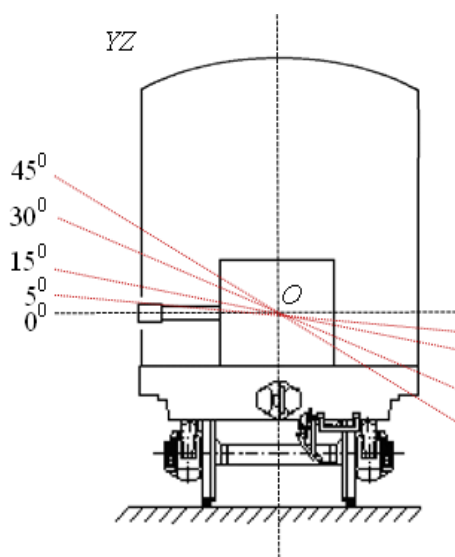

Figure 8. Scheme of conducting fire from the military equipment.

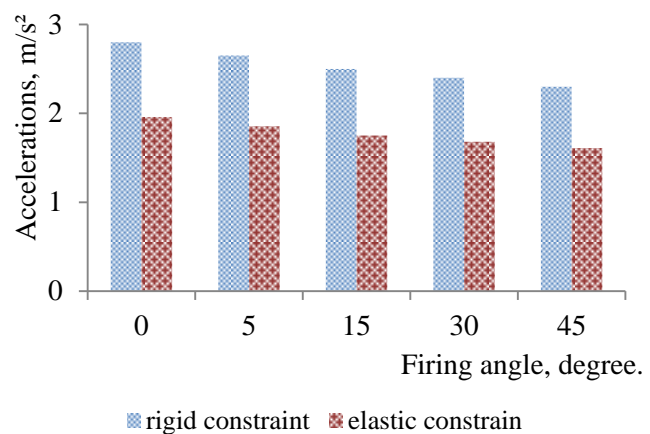

Figure 9. Accelerations acting on the wagon supporting structure in the horizontal plane.

It can be seen from Figure 10 that the magnitude of the horizontal accelerations decreases when the firing angle increases. In this case, the value of vertical accelerations increases slightly.

3. The main strength indicators determination of supporting structure of a covered wagon for the military equipment transportation and for conducting fire

To determine the strength of the covered wagon supporting structure, a finite element analysis has been performed using the CosmosWorks software [12 – 15]. When creating a finite element model, spatial isoparametric tetrahedrons have been used. The optimal number of elements was determined by

the graphical analytical method [16 – 19].

The finite element model of the covered wagon supporting structure is shown in Figure 10. The number of nodes in the model is 241723, and the number of elements is 693226. The maximum element size is 80 mm, and the minimum one is 16 mm. The percentage of elements with an aspect ratio of less than three is 18.8 and the percentage of elements with an aspect ratio of more than ten is 33.6. The minimum number of elements in a circle is 22; and the ratio of increasing the elements size is 1.8. The material of the wagon supporting structure is steel 09G2S. The model was fixed in the zones of supporting on the bogies.

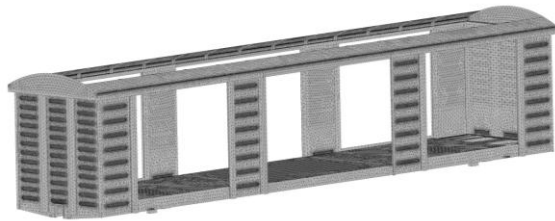

Figure 10. Finite-element model of the covered wagon supporting structure.

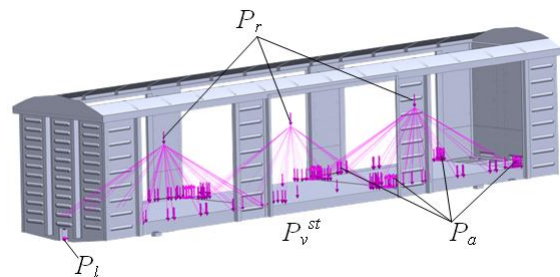

Figure 11. Design scheme of the covered wagon supporting structure.

When drawing up the design diagram of the covered wagon supporting structure, it has been taken into account that a vertical static load P_v^{st} and the load acting on the support areas when firing, which was considered as a remote one P_y , act on it (Figure 11). It is taken into account that the longitudinal load P_t , which is assumed to be 2.5 MN, acts on the front stops of the automatic coupling. The forces acting on the support areas P_a in the places where military equipment is attached to them are also taken into account. This force was decomposed into components, taking into account the angles of the fixing means in space.

The calculation results made it possible to establish that the maximum equivalent stresses are concentrated in the area of the front stops and are about 315 MPa (Figure 12) and do not exceed the permissible values [20 – 22]. The maximum displacements are about 3 mm (Figure 13). The maximum deformations are $5.46 \cdot 10^{-3}$.

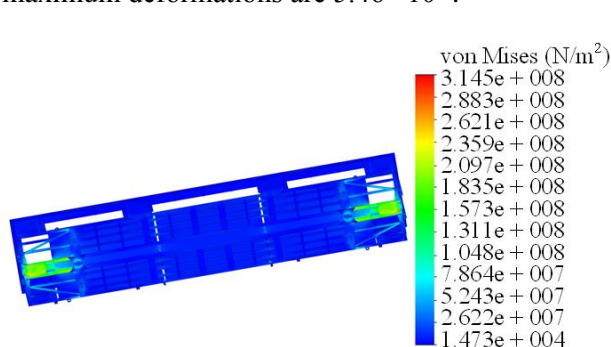

Figure 12. Stress state of the covered wagon supporting structure (bottom view).

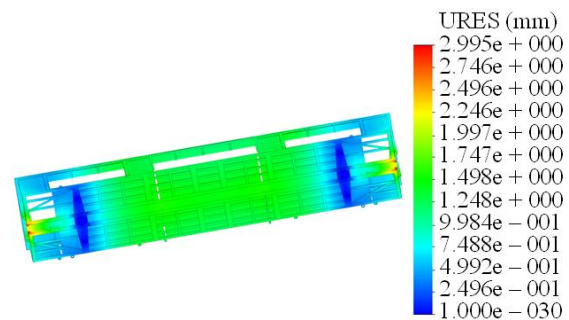

Figure 13. Displacements in the nodes of the covered wagon supporting structure (bottom view).

Also, within the framework of the study, a modal analysis of the supporting structure of a covered wagon has been carried out. The values of natural oscillation frequencies are within the permissible limits, since the first natural frequency has a value of more than 8 Hz [18, 19].

Conclusions

1. A computer model of the supporting structure of a covered wagon for military equipment transportation and for conducting fire has been created. A special feature of the wagon is that its

supporting structure has a sliding roof, which allows conducting fire in a vertical plane. The wagon supporting structure is equipped with a movable double-folding door for loading military equipment, as well as for conducting fire in a horizontal plane. Military equipment is placed on special support areas on the wagon frame.

2. Dynamic loading mathematical simulation of the supporting structure of a covered wagon for transporting military equipment and for conducting fire has been carried out. The studies have been carried out in a plane coordinate system. It has been taken into account that the muzzle energy of one piece of military equipment is about 90 kJ. It was found that the accelerations acting on the wagon supporting structure in the vertical plane are about 6.0 m/s^2 (0.6 g). The accelerations are 2.6 m/s^2 (0.26 g) in the horizontal plane. That is, the wagon motion can be assessed as “satisfactory”.

In order to reduce the wagon dynamic loading during conduct of the fire while moving, the case of installing elastic vibration absorbers under the support areas has been also considered. The results of the calculation made it possible to establish that the stiffness of the impact absorbers should be in the range from 3 kN/m to 10 kN/m. When using impact absorbers in the support areas, the wagon dynamic load is reduced by about 25%. in comparison with the case of the rigid interaction of the sector with the frame.

3. Determination of the main strength indicators of the load-bearing structure of a covered wagon for military equipment transportation and for conducting fire has been carried out. The calculation has been carried out using the finite element method in the CosmosWorks software. The calculation results made it possible to establish that the maximum equivalent stresses are concentrated in the area of the front stops and are about 315 MPa. The maximum displacements are about 3 mm. The maximum deformations are $5.46 \cdot 10^{-3}$.

The numerical values of the natural oscillation frequencies of the covered wagon supporting structure during conduct of the fire have been determined. It was found that the values of natural oscillation frequencies are within the permissible limits.

The conducted research will contribute to the creation of recommendations for designing of covered wagons for military equipment transportation and for conducting fire, as well as to increasing the efficiency of the railway transport operation.

Acknowledgments

This study was conducted in the framework of a scientific theme "Development of conceptual frameworks for restoring the efficient operation of obsolete freight cars" (Project registration number: 2020.02/0122).

References

- [1] Bityuckij A A, Afanasev, Hilov I A and Guskov V I 2015 Stendovye ispytaniya na soprotivlenie ustalosti maketnyh uzlov krytogo vagona dlya perevozki avtomobilej Transport Rossijskoj Federacii **3(58)** pp 81–85
- [2] Chepurnoj A D, Litvinenko A V, Baranov A N, Shejchenko R I and Bondarenko M A 2014 Eksperimentalnye issledovaniya gruzovogo vagona Visnik NTU «HPI» **22 (1065)** pp 44–61
- [3] Chepurnoj A D, Shejchenko R I, Graborov R V, Tkachuk N A, Bondarenko N A., Grabovskij A V and Lunev E A 2017 Chislennye issledovaniya gruzovogo vagona Visnik NTU "HPI" **23 (1245)** pp 47–55
- [4] Boronenko Yu P and Filippova I O 2015 Ispolzovanie vysokoprochnnyh stalej v vagonostroenii Transport Rossijskoj Federacii **3(58)** pp 16–19
- [5] Raffaele Sepe and Angela Pozzi 2015 Static and modal numerical analyses for the roof structure of a railway freight refrigerated car *R. Sepe et alii, Frattura ed Integrità Strutturale* **33** pp 451–462. doi: 10.3221/IGF-ESIS.33.50
- [6] Hyun-Ah Lee, Seong-Beom Jung, Hwan-Hak Jang, Dae-Hwan Shin, Jang Uk Lee, Kwang Woo Kim and Gyung-Jin Park 2016 Structural-optimization-based design process for the body of a railway vehicle made from extruded aluminum panels *Journal of Rail and rapid transit* **11**
- [7] Fomin O, Lovska A, Pištěk V and Kučera P 2020 Research of stability of containers in the

- combined trains during transportation by railroad ferry *MM SCIENCE JOURNAL* **1** pp 3728 – 3733
- [8] Fomin O, Lovska A 2020 Improvements in passenger car body for higher stability of train ferry *Engineering Science and Technology an International Journal* <https://doi.org/10.1016/j.jestch.2020.08.010>
- [9] Kliuiev S 2018 Experimental study of the method of locomotive wheel-rail angle of attack control using acoustic emission *Eastern-European Journal of Progressive Technologies* **2/9 (82)** pp 69–75 doi: 10.15587/1729-4061.2018.122131
- [10] Kondratiev A V, Gaidachuk V E, Kharchenko M E 2019 Relationships between the ultimate strengths of polymer composites in static bending, compression, and tension *Mechanics of Composite Materials* **52 2** pp 259–266
- [11] Pistek V, Klimes L, Mauder T and Kucera P 2017 Optimal design of structure in rheological models: An automotive application to dampers with high viscosity silicone fluids *Journal of Vibroengineering* **19 6** pp 4459–4470
- [12] Alyamovskiy A A 2007 SolidWorks/COSMOSWorks 2006 – 2007 Inzhenernyy analiz metodom konechnykh elementov (Cham: Moscow DMK) p 784
- [13] Alyamovskiy A A 2010 COSMOSWorks Osnovy rascheta konstruktsiy na prochnost v srede SolidWorks (Cham: Moscow DMK Press) p 785
- [14] Dižo J, Steišunas S, Blatnický M 2016 Simulation analysis of the effects of a rail vehicle running with wheel flat *Manufacturing Technology* **16 5** pp 889-896
- [15] Dižo J, Harušinec J, Blatnický M 2015 Multibody system of a rail vehicle bogie with a flexible body *Manufacturing Technology* **15 5** pp 781-788
- [16] Fomin O, Lovska A, Pištěk V and Kučera P 2019 Dynamic load computational modelling of containers placed on a flat wagon at railroad ferry transportation *VIBROENGINEERING PROCEDIA* **29** pp 118–123
- [17] Vatulia G L, Lobiak O V, Deryzemlia S V, Verevicheva M A and Orel Ye F 2019 Rationalization of cross-sections of the composite reinforced concrete span structure of bridges with a monolithic reinforced concrete roadway slab *IOP Conference Series: Materials Science and Engineering* **664** 012014 doi:10.1088/1757-899X/664/1/012014
- [18] Fomin O, Lovska A, Radkevych V, Horban A, Skliarenko I and Gurenkova O 2019 The dynamic loading analysis of containers placed on a flat wagon during shunting collisions *ARP Journal of Engineering and Applied Sciences* **14 21** pp 3747–3752
- [19] Vatulia G, Komagorova S, Pavliuchenkov M 2018 Optimization of the truss beam. Verification of the calculation results *MATEC Web of Conferences* **230** 02037 doi: 10.1051/mateconf/201823002037
- [20] DSTU 7598:2014 2014 Vagoni vantazhni. Zagalni vimogi do rozrahunkiv ta proektuvannya novih i modernizovanih vagoniv koliyi 1520 mm (nesamohidnih) p 162
- [21] GOST 33211-2014 2014 Vagonyi gruzovyye. Trebovaniya k prochnosti i dinamicheskim kachestvam p 54
- [22] DIN EN 12663-2-2010 2010 Railway applications – Structural requirements of railway vehicle bodies – Part 2: Freight wagons p 54